

MECBO



GETTO MAXI



PULSAR SYSTEM

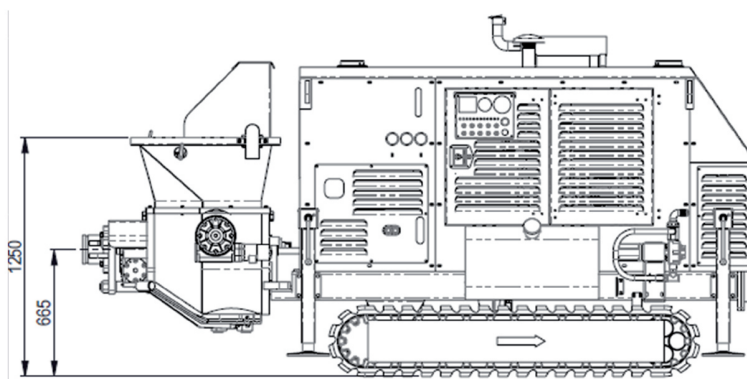
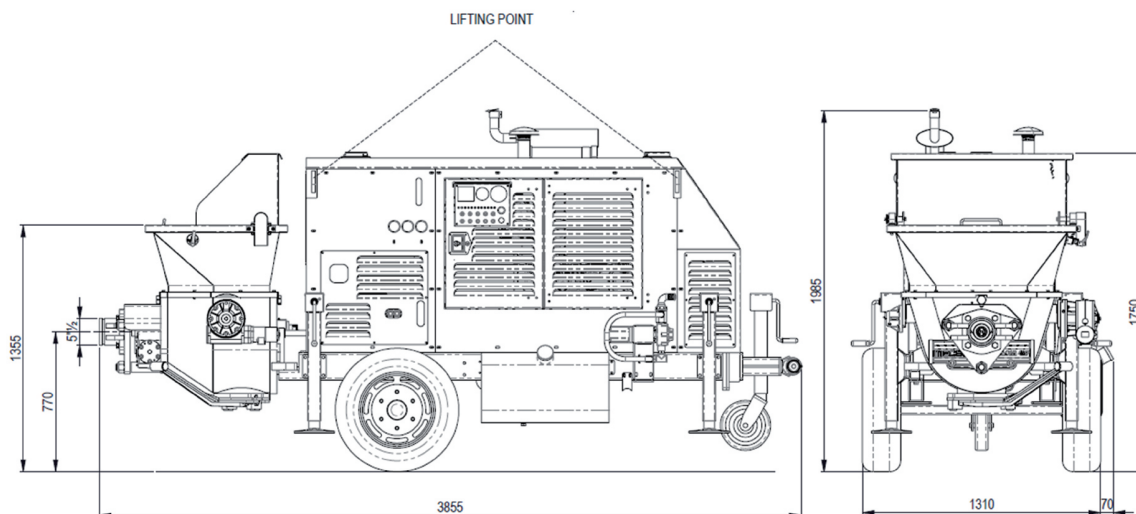

CARATTERISTICHE TECNICHE – TECHNICAL PERFORMANCES CARACTERISTIQUES TECHNIQUES – TECHNISCHE DATEN

		GETTO MAXI	GETTO MAXI TRK
Portata Calcestruzzo – Concrete Output Débit Béton - Beton Fördermenge	m³/h		30
Pressione in Uscita - Outlet Pressure Pression sortie – Ausgang Betondruck	bar	55-70	
Capacità della Tramoggia - Hopper Capacity Capacité Trémie – Kapazität des Trichters	lt	330	
Diametro Cilindri Pomp. - Pumping Cylinders Diameter Diamètre Cylindres de pompage - Zylindersdurchmesser	mm	150	
Corsa Pistoni Pompanti - Pumping Cylinders Stroke Course Cylindres de Pompage - Schlaganfall	mm	1000	
Diametro Uscita - Outlet Diameter Diamètre Sortie - Austrittsdurchmesser	mm	125 / 5” ¹ / ₂	
Motore Diesel o Elettrico – Diesel or Electric Motor Moteur Diesel ou Electrique – Diesel oder Elektromotor	Kw / hp	38 / 51	
Capacità serbatoio olio - Oil Tank Capacity Capacité Réservoir Huile - Oiltank Kapazität	lt	120	
Compressore Aria - Air Compressor Compresseur d’Air - Luftkompressor	Lt/m³-bar	1000 - 10	
Pompa Acqua - Water Pump Pompe à Eau - Wasserpumpe	Lt/m³-bar	36 - 16	
Peso Approssimativo - Approx. Weight Poids Approx. - Gewicht ca..	kg	2350	2900
Velocità Cingolo – Crawler Speed Vitesse Chenilles - Bahngeschwindigkeit	Km/h		2 / 2,5

OPTIONAL – EN OPTION FAKULTATIV

POMPA ACQUA - WATER PUMP POMPE A EAU - WASSERPUMPE
COMPRESSORE - COMPRESSOR COMPRESSEUR - KOMPRESSOR
VIBRATORE - VIBRATOR VIBRATEUR - VIBRATOR
RADIO COMANDO RADIO REMOTE CONTROL RADIOCOMMANDE RADIO FERNSTEUERUNG
INSONORIZZAZIONE - SOUNDPROOFING INSONORISATION - SCHALLDÄMMUNG
ACCESSORI SPRITZ-BETON SHOT-CRETE ACCESSORIES ACCESSOIRES POUR PROJECTION SPRITZ-BETON ZUBEHÖRE
TUBAZIONE E ACCESSORI PIPELINES AND ACCESSORIES TUYAUTERIES ET ACCESSOIRES ROHRLEITUNG UND ZUBEHÖRE

I presenti dati tecnici hanno valore indicativo. Con l'evolversi della tecnologia, i dati esposti potranno subire modifiche senza preavviso. Le richieste tecniche specifiche debbono essere sempre accettate dalla nostra Direzione con conferma scritta. The present technical data have indicative value. Owing the technology development, all above mentioned details maybe changed without any notice. All specific technical request must be always accepted from our Management by written confirmation.