

MECBO



SCORPION

CRAWLER DISTRIBUTOR BOOM

Track
Distributor boom
Pipeline

SC5-25
A-17/100
DIN100



PULSAR SYSTEM

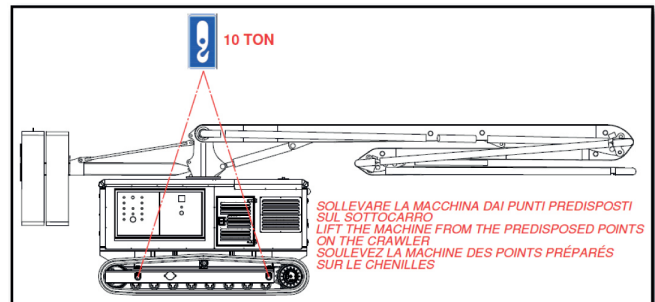
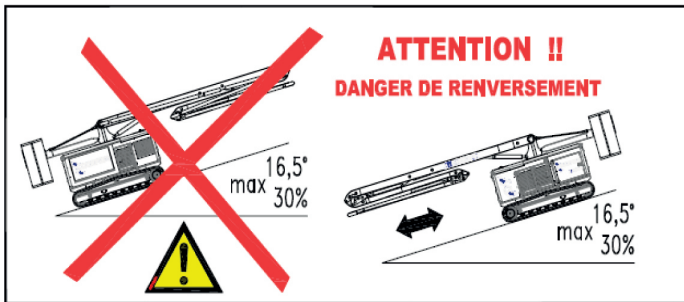
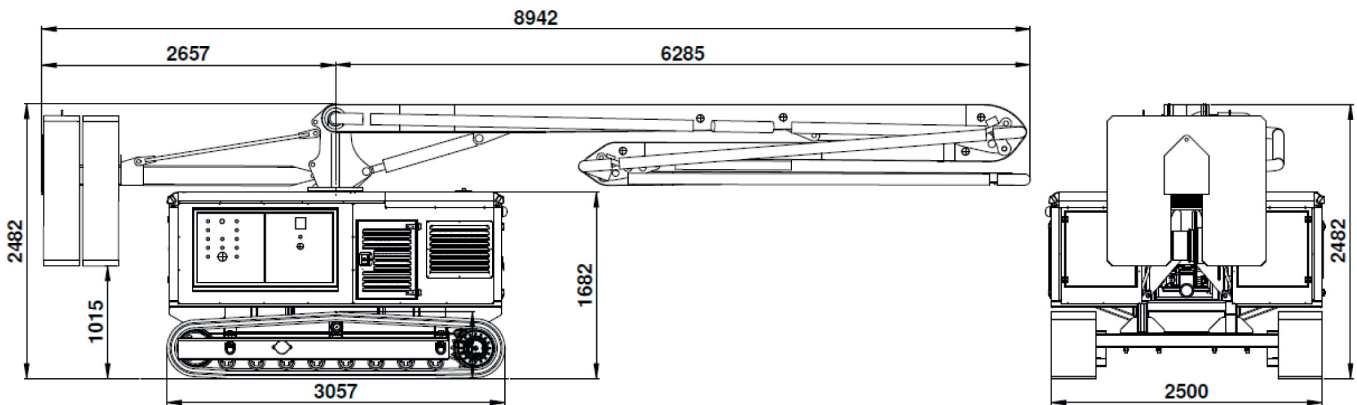

CARATTERISTICHE TECNICHE – TECHNICAL PERFORMANCES CARACTERISTIQUES TECHNIQUES – TECHNISCHE DATEN

Diametro tubazione – Pipeline diameter Diamètre de la tuyauterie – Förderleitung Durchmesser	100 mm
Raggio orizzontale – Horizontal reach Portée horizontale – Horizontalablenkung	14 m
Altezza massima – Max. vertical reach Portée verticale – Max. Höhe	16,2 m
Min. altezza apertura – Min. opening height Min. hauteur d'ouverture – Min. Öffnungshöhe	4,4 m
Numero di sfili – Sections Number Nombre de sections – Anzahl der Abschnitte	3 Z
Rotazione torretta – Slewing range Rotation de la tourelle – Turmdrehung	370°
Pressione oleodinamica – Hydraulic pressure Pression hydraulique – Hydraulikdruck	300 bar
Motore Diesel – Diesel Motor Moteur Diesel – Diesel motor	22 Kw
Motore Elettrico – Electric Motor Moteur Electrique – Elektromotor	37 Kw
Tensione imp. Elettrico Electrical voltage Tension électrique Spannung des Elektr. System	24V (dc) 400V (ac)
Capacità serbatoio olio – Oil Tank Capacity Capacité Réservoir Huile – Oiltank Kapazität	160 lt
Peso Totale – Total Weight Poids Total – Gesamtgewicht	10 ton
Peso Zavorre – Ballast Weight Poids Ballast – Ballast Gewicht	2800 kg
Velocità Cingolo – Crawler Speed Vitesse Chenilles – Bahngeschwindigkeit	2-2,5 Km/h

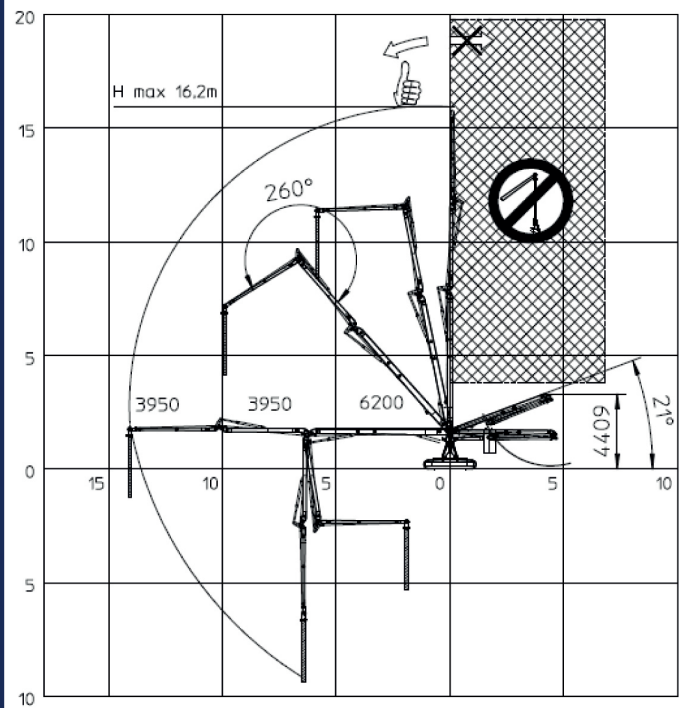

Inclusi nella fornitura radiocomando per movimentazione braccio e sottocarro, motore diesel insonorizzato, avvolgicavo a molla.

Supplied with wireless radio control for boom and crawler, soundproof diesel engine, spring cable reel.

Inclus radiocommande pour fleché et chenilles, moteur diesel insonorisé, enrouleur de câble à ressort.

Inbegriffen Radio-Fernbedienung für die Handhabung von Armen und Fahrwerken enthalten, schallgedämpfter Dieselmotor, Federleitungstrommel.

I presenti dati tecnici hanno valore indicativo. Con l'evolversi della tecnologia, i dati esposti potranno subire modifiche senza preavviso. Le richieste tecniche specifiche debbono essere sempre accettate dalla nostra Direzione con conferma scritta. The present technical data have indicative value. Owing to the technology development, all above mentioned details may be changed without any notice. All specific technical request must be always accepted from our Management by written confirmation.